

Unit: mm

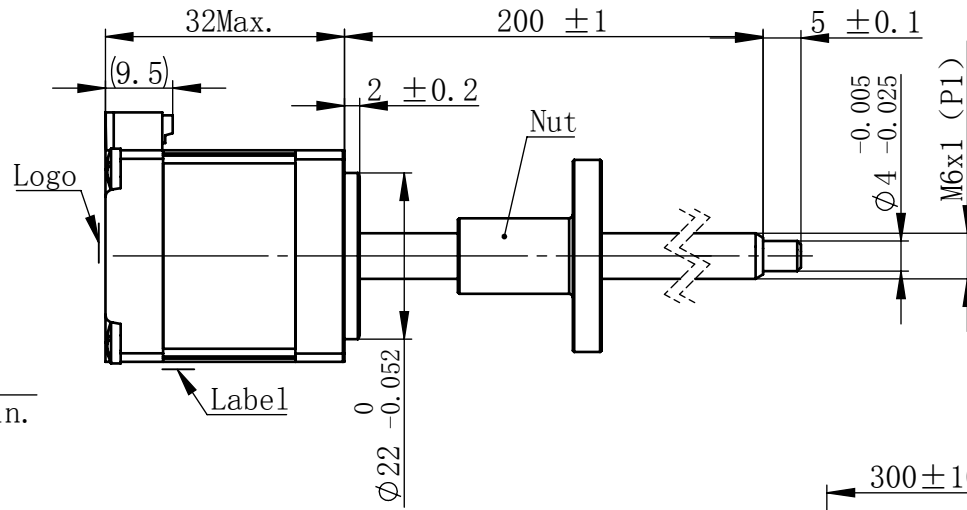

Nut

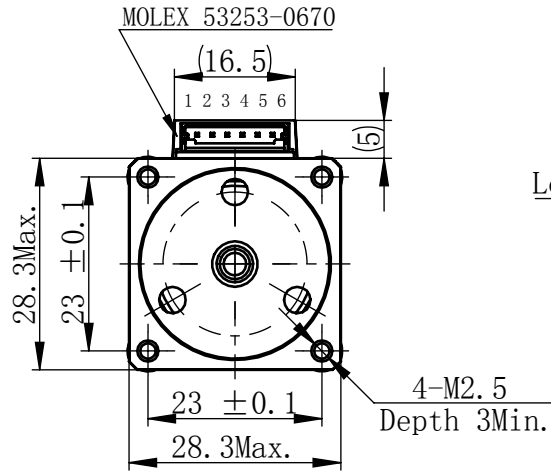
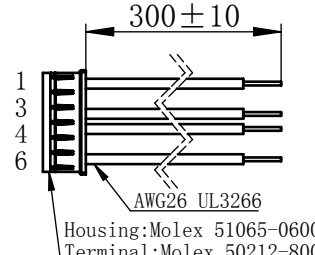
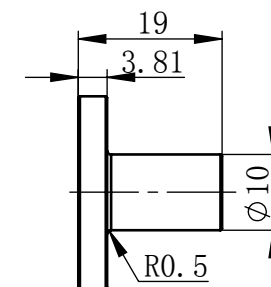
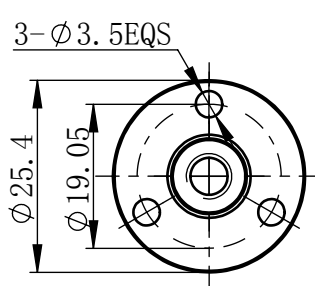

连接器针位vs. 引线颜色  
Pin No. vs. Lead Wire Colour

Pin No.	颜色 Colour
1	黑 BLA
3	绿 GRN
4	红 RED
6	蓝 BLU

接线图  
Wiring Diagram

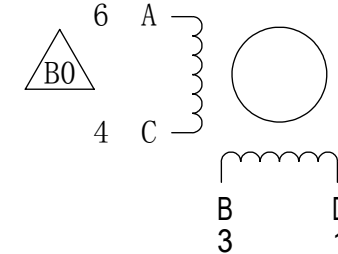

励磁顺序 vs. 旋转方向  
Exciting Sequence vs. Direction of Rotation

STEP	A	B	C	D	
1	+	+	-	-	↑ CCW ↓ CW
2	-	+	+	-	
3	-	-	+	+	
4	+	-	-	+	

从安装面看为顺时针方向  
Clockwise view from mouting side

电机标签  
Motor label

LEAD SCREW MOTOR  
11E3210W1-200-G  
XXXXXXXX

批次号

备注Note:  
螺纹丝杆及螺母在正常使用过程中,  
若有少许粉尘掉落为正常现象。  
It's normal phenomenon if there is a little dust  
fall off when using the lead screw and nut.

规格  
Specifications

1	相数 Number Of Phase	2
2	步长 Linear Travel/Step	0.005 mm (1.8°)
3	额定电压 Rated Voltage	2.7 V DC
4	额定电流 Rated Current	1 Amp
5	额定推力 Rated Thrust	46 N(@300rpm, rated current)
6	相电阻 Phase Resistance	2.7 ohm ± 10% (20°C)
7	相电感 Phase Inductance	2.5 mH ± 20% (1kHz 1V rms)
8	转子惯量 Rotor Inertia	9 gcm <sup>2</sup>
9	重量 Weight	0.1 Kg
10	绝缘等级 Insulation Class	B(130°C)
11	丝杠直径 Screw Diameter	6 mm
12	丝杠导程 Lead	1 mm

版本变更

版本	变更说明	签名	日期
B0			

未标注线性尺寸和公差  
Tolerance for linear and dimensions  
without individual tolerance indications  
GB/T 1804-M eqv ISO 2768-1:M

未标注形状与位置尺寸公差  
Geometrical tolerance for features  
without individual tolerance indications  
GB/T 1184-K eqv ISO 2768-2:K

- I. 请避免螺母脱离丝杠  
Keep nut on screw.
- II. 非专业人士请勿拆解电机  
Avoid disassembly without  
qualification.

设计  
Design

校核  
Check

工艺  
Process

标准化  
Standard

批准  
Approve

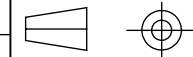

First Angle Method

材料  
Material

总图

Page 1 of 1

版本  
Version



www.hdbmotors.com

比例 Scale	零件名 Part Name	直线步进电机
1:1	型号 Model NO.	11E3210W1-200-G
	物料号 Material NO.	