

Unit: mm

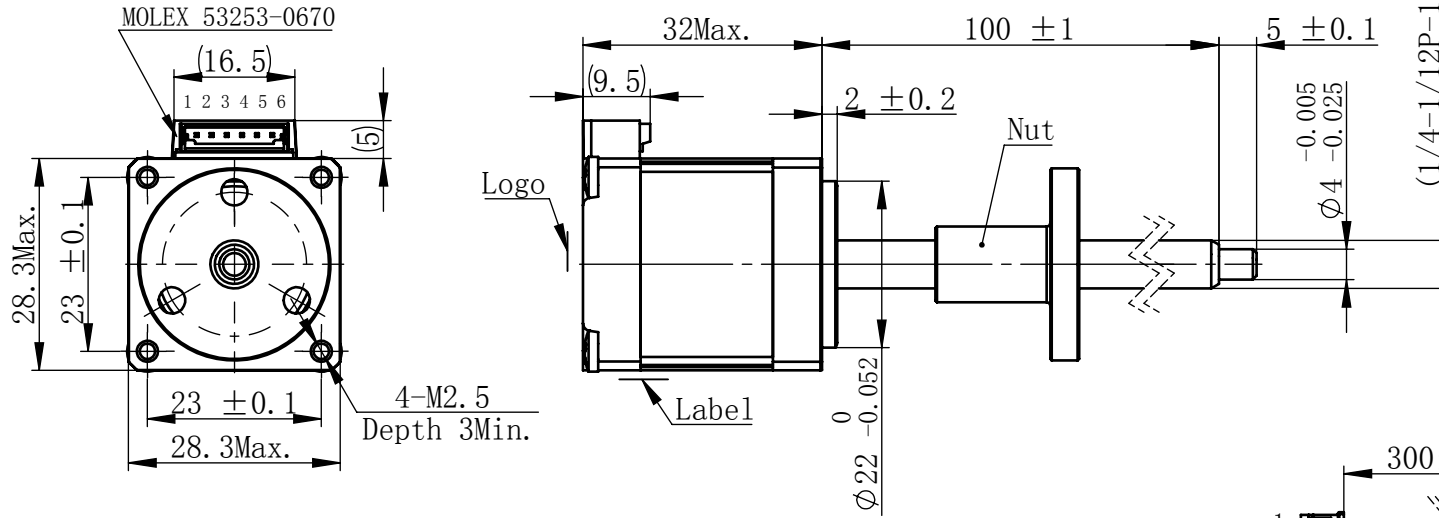

接线图
Wiring Diagram

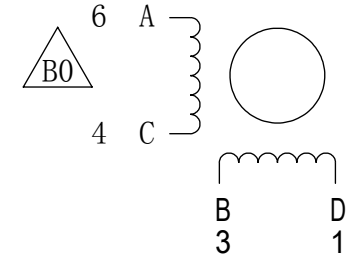

励磁顺序 vs. 旋转方向
Exciting Sequence vs. Direction of Rotation

STEP	A	B	C	D
1	+	+	-	-
2	-	+	+	-
3	-	-	+	+
4	+	-	-	+

从安装面看为顺时针方向
Clockwise view from mouting side

电机标签
Motor label

LEAD SCREW MOTOR
11E3210E19-100-G
XXXXXXXX

批次号

备注Note:
螺纹丝杆及螺母在正常使用过程中,
若有少许粉尘掉落为正常现象。
It's normal phenomenon if there is a little dust
fall off when using the lead screw and nut.

规格
Specifications

1	相数 Number Of Phase	2
2	步长 Linear Travel/Step	0.0635 mm (1.8°)
3	额定电压 Rated Voltage	2.7 V DC
4	额定电流 Rated Current	1 Amp
5	额定推力 Rated Thrust	6 N@300rpm, rated current)
6	相电阻 Phase Resistance	2.7 ohm ± 10% (20°C)
7	相电感 Phase Inductance	2.5 mH ± 20% (1kHz 1V rms)
8	转子惯量 Rotor Inertia	9 gcm ²
9	重量 Weight	0.1 Kg
10	绝缘等级 Insulation Class	B(130°C)
11	丝杠直径 Screw Diameter	6.35 mm
12	丝杠导程 Lead	12.7 mm

版本变更

版本	变更说明	签名	日期
B0			

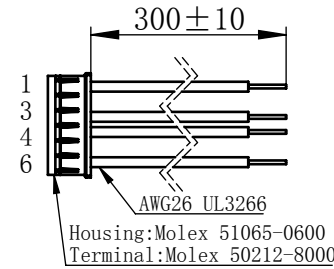
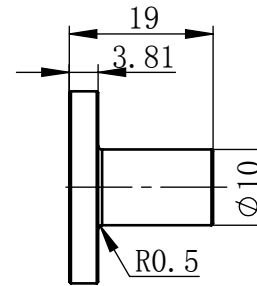
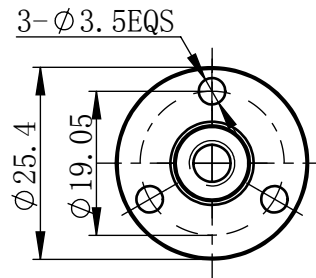

连接器针位 vs. 引线颜色
Pin No. vs. Lead Wire Colour

Pin No.	颜色 Colour
1	黑 BLA
3	绿 GRN
4	红 RED
6	蓝 BLU

未标注线性尺寸和公差
Tolerance for linear and dimensions
without individual tolerance indications
GB/T 1804-M eqv ISO 2768-1:M

未标注形状与位置尺寸公差
Geometrical tolerance for features
without individual tolerance indications
GB/T 1184-K eqv ISO 2768-2:K

- I. 请避免螺母脱离丝杠
Keep nut on screw.
- II. 非专业人士请勿拆解电机
Avoid disassembly without
qualification.

设计
Design

校核
Check

工艺
Process

标准化
Standard

批准
Approve

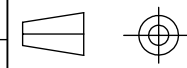

First Angle Method

材料
Material

总图

Page 1 of 1

版本
Version



www.hdbmotors.com

比例
Scale

1:1

零件名
Part Name

直线步进电机

型号
Model NO.

11E3210E19-100-G

物料号
Material NO.